



*County of Gloucester  
Codes Compliance – Building Inspections  
Building Three  
P. O. Box 604  
Gloucester, Virginia 23061*

July 8, 2008

RE: WOODSTOVE INSTALLATION GUIDE

TO: Designers/Design Professionals, Builders/Contractors, Citizens, Applicants & County Staff

This document is intended to be a guide for meeting minimum code requirements when installing a woodstove without manufacturers' installation instructions. This document is generic and may not fit every situation or appliance. The appliance should still be listed and labeled, and whenever possible every effort should be made to obtain the original installation instructions from the manufacturer of the appliance. A full version of the document excerpted to compile this guide is available to view free online at: <http://nfpaweb3.gvpi.net/rrserver/browser?title=/NFPASTD/21106>. This document is produced by the National Fire Protection Agency. The version used is the 2006 edition.

Anthony V. McMahan  
Plumbing/Mechanical Inspector

Paul F. Koll  
Building Official

**3.3.153 Type BW Gas Vent.** See 3.3.159.1.3.

**3.3.154 Type HT Factory-Built, Residential-Type and/or Building Heating Appliance Type Chimney.** See 3.3.32.1.3.

**3.3.155 Type L Vent.** See 3.3.159.3.

**3.3.156 Unit.**

**3.3.156.1 Solid Masonry Unit.** A masonry unit whose net cross-sectional area in every plane parallel to the bearing surface is 75 percent or more of its gross cross-sectional area measured in the same plane.

**3.3.156.2 Steel Fireplace Unit.** A unit consisting of a steel firebox and an air chamber adjacent to the sides and rear of the firebox, used to construct a masonry fireplace. The unit usually has ducts to circulate air to and heated air from the air chamber to the living space.

**3.3.157 Unit Heater.** See 3.3.98.2.

**3.3.158 Unlisted Metal (Smokestack) Chimney.** See 3.3.32.6.

**3.3.159\* Vent.** A flue gas-conveying system intended for use only with certain gas, liquid, or pellet fuel-fired appliances that do not produce flue gas outlet temperatures higher than a value specified in the listing vent standards.

**3.3.159.1 Gas Vent.** A passageway composed of listed factory-built components assembled in accordance with the terms of listing for conveying vent gases from gas appliances or their vent connectors to the outside atmosphere. [54, 2006]

**3.3.159.1.1 Special Gas Vent.** A gas vent for venting listed Category II, III, and IV gas appliances.

**3.3.159.1.2 Type B Gas Vent.** A vertical or nearly vertical gas vent for venting listed gas appliances with draft hoods and other Category I gas appliances listed for use with Type B gas vents.

**3.3.159.1.3 Type BW Gas Vent.** A vertical or nearly vertical gas vent for venting listed gas-fired vented wall furnaces.

**3.3.159.2 Pellet Vent.** A venting system composed of listed, factory-built components assembled in accordance with the manufacturer's instructions for conveying flue gases from a listed pellet fuel-burning appliance to the outside atmosphere.

**3.3.159.3 Type L Vent.** A vertical or nearly vertical vent composed of listed factory-built components assembled in accordance with the terms of listing for conveying flue gases from oil and gas appliances or their vent connectors to the outside atmosphere.

**3.3.160 Vent Cap.** See 3.3.22.2.

**3.3.161 Vent Connector.** See 3.3.52.2.

**3.3.162 Vent Gases.** See 3.3.91.2.

**3.3.163 Vented Appliance.** See 3.3.3.12.

**3.3.164 Venting.** Removal of combustion products as well as noxious or toxic fumes to the outside atmosphere.

**3.3.165 Venting System (Flue Gases).** See 3.3.147.2.

**3.3.166 Wall Furnace.** See 3.3.88.14.

**3.3.167 Wall Protector (Shield).** Noncombustible surfacing applied to a wall area for the purpose of reducing the clearance between the wall and a heat-producing appliance.

**3.3.168 Wash.** A slight slope or beveled edge on the top surface of a chimney designed to shed water away from the flue liner; also called a *splay*.

**3.3.169 Water Heater.** See 3.3.98.3.

**3.3.170 Wythe.** Where referring to masonry chimneys, a course, a thickness, or a continuous vertical section of masonry separating flues in a chimney.

## Chapter 4 General Requirements

### 4.1\* Sizing and Draft.

**4.1.1 Minimum Performance.** A chimney or vent shall be so designed and constructed to develop a flow sufficient to remove completely all flue or vent gases to the outside atmosphere.

**4.1.1.1** Chimneys or vents shall be evaluated to ensure proper performance with respect to draft, creosote buildup, and condensation.

**4.1.1.2** The venting system shall satisfy the draft requirements of the connected appliance(s) in accordance with the manufacturers' instructions or approved methods.

**4.1.2 Mechanical Draft Systems.** A listed mechanical draft system of either forced or induced draft design shall be permitted to be used to increase draft or capacity.

**4.1.2.1** Where a mechanical draft system is installed, provision shall be made to prevent the flow of fuel to an automatically fired appliance(s) when that system is not operating.

**4.1.2.2** The operation of a mechanical draft system shall not adversely affect the performance or safety of, or cause spillage of combustion products from, other combustion equipment operating within the same building.

**4.1.2.3** Proper performance and safety of other combustion equipment shall be verified by testing prior to the mechanical draft system being put into service.

**4.1.2.4** Such testing shall include operation of the mechanical draft system together with other exhaust equipment likely to operate simultaneously.

**4.1.2.5** Mechanical draft systems of either forced or induced draft serving manually fired appliances shall be one of the following:

- (1) A mechanical draft system that is an integral part of a listed appliance
- (2) A solid fuel cooking appliance as addressed in NFPA 96, *Standard for Ventilation Control and Fire Protection of Commercial Cooking Operations*
- (3)\*An engineered mechanical draft system that includes the following provisions:
  - (a) The following detection and warning devices shall be installed and line voltage devices, when installed, shall be provided with a battery backup system:
    - i. A device that produces an audible and visible warning upon failure of the mechanical draft system. The device shall be activated by loss of electrical power supply or by operational failure of the mechanical draft system at any time while the mechanical draft system is switched on.

- ii. A smoke detector and alarm installed and maintained in accordance with *NFPA 72, National Fire Alarm Code*. The detector shall be installed in the same room as the appliance served by the mechanical draft system.
- iii. A listed carbon monoxide warning device installed in accordance with the manufacturer's instructions.
- (b) The mechanical draft system shall be listed in accordance with *UL 378, Standard for Draft Equipment*, for use with the type of appliance and range of chimney service appropriate for the application. The mechanical draft system shall not cause or permit blockage of the flue or electrical hazard after exposure to a chimney fire or over fire conditions. The mechanical draft system shall be installed in accordance with the terms of the listing and the manufacturer's instructions.
- (c) The mechanical draft system shall be sized to maintain draft within the range specified by the appliance manufacturer.

**4.1.3 Natural Draft Sizing.** Chimneys serving incinerators or other process equipment where the combustion process cannot be stopped completely by fuel shutoff alone shall be sized for natural draft conditions.

**4.1.3.1** Where air pollution control devices or other devices in the chimney system require a mechanical draft system, the chimney system shall be so arranged that, upon a power failure, the natural draft chimney alone can satisfactorily remove the products of combustion until the combustible material is completely consumed.

**4.1.4 Forced/Induced Draft Systems.** Forced draft systems and all portions of induced draft systems under positive pressure during operation shall be designed and installed to be gastight or to prevent the leakage of combustion products into a building.

**4.1.5 Natural Draft Vent Connectors.** Vent connectors serving appliances vented by natural draft shall not be connected into any portion of mechanical draft systems operating under positive pressure.

**4.2 Termination (Height).** Chimneys and vents shall terminate above the roof level in accordance with the requirements of this standard and as illustrated in Figure 4.2(a) and Figure 4.2(b).

**4.2.1** Masonry chimneys shall extend above the highest point at which they pass through the roof of a building by at least the distance specified in Table 7.2, Column VI, and shall also extend at least the specified distance above any portion of any structure within the specified proximity (measured horizontally from the vertical chimney line) in Table 7.2, Column VII.

**4.2.2** Natural draft chimneys and vents shall not terminate at an elevation less than 5 ft (1.53 m) above the flue collar or the highest connected draft hood outlet.

*Exception: As provided in Section 10.7.*

**4.3 Enclosure.**

**4.3.1 General.** Interior residential chimneys shall be enclosed where they extend through closets, storage areas, or habitable spaces where the surface of the chimney could come into contact with persons or combustible materials.

**4.3.2 Clearance.** The space between the chimney and the enclosure shall be at least the minimum air space clearance specified in this standard (see Table 7.2) or the clearance specified in the manufacturer's instructions for listed chimneys.

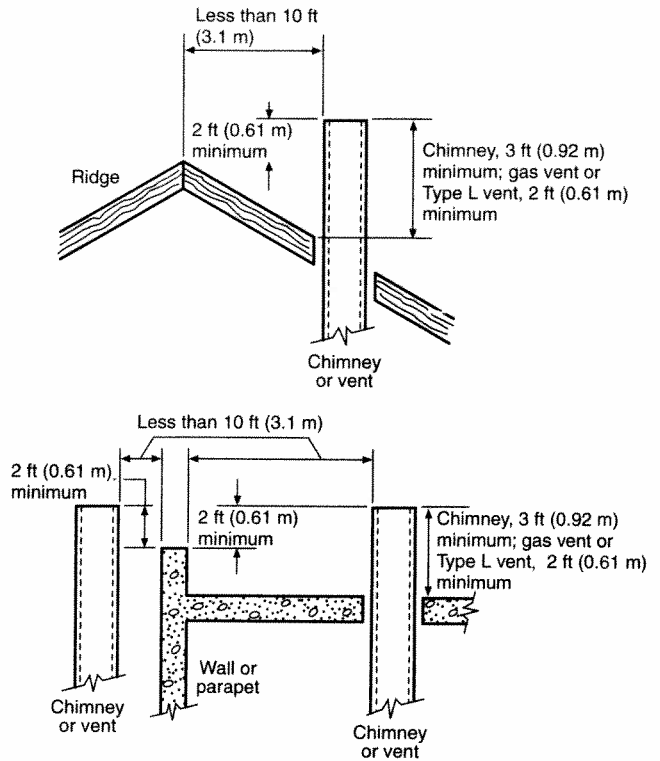

**FIGURE 4.2(a) Chimney or Vent Termination Less Than 10 ft (3.1 m) from Ridge, Wall, or Parapet.**

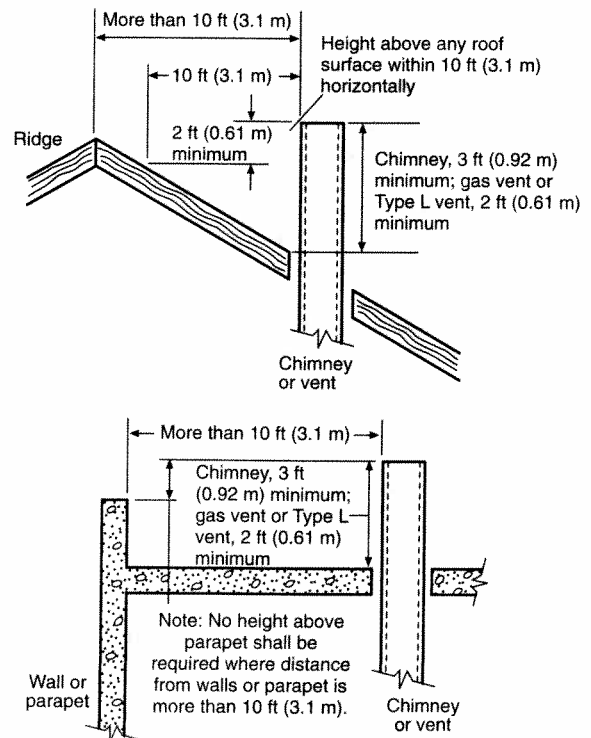

**FIGURE 4.2(b) Chimney or Vent Termination More Than 10 ft (3.1 m) from Ridge, Wall, or Parapet.**

#### 4.4 Venting Systems in Ducts.

**4.4.1 Circulating Air Ducts and Plenums.** No portion of a venting system shall extend into or pass through a dedicated circulating air duct or plenum.

**4.4.2 Above-Ceiling Spaces.** Where a venting system passes through a space above a ceiling used as a return air plenum, it shall be installed according to one of the following methods:

- (1) With joints within the above-ceiling return air plenum sealed airtight in a manner approved by the manufacturer of the venting system
- (2) As a listed positive-pressure venting system
- (3) Non-airtight venting system installed with no joints or fittings located within the above-ceiling return air plenum

#### 4.5 Flue Lining.

**4.5.1 Resistance Equivalency.** Castable or plastic refractories used to line chimneys or connectors shall be the equivalent in resistance to heat and erosion by flue gases to that of the fire-clay brick.

**4.5.2 Lining Support.** Lining made of castable or plastic refractories shall be secured to the supporting walls by anchors made of corrosion-resistant steel capable of supporting the refractory load at 1500°F (816°C).

**4.5.3 Space Surrounding Liner or Vent.** The remaining space surrounding a chimney liner, gas vent, special gas vent, or plastic piping installed within a chimney flue shall not be used to vent another appliance.

#### 4.6 Caps and Spark Arresters for Chimneys and Vents.

**4.6.1 Design.** Chimney or vent caps, where required for the termination of chimneys or vents, shall be designed to prevent the entry of rain, snow, birds, and other animals.

**4.6.2 Screening.** Screening material attached to chimney or vent caps to prevent the entry of animals and insects shall not adversely affect the chimney or vent draft.

#### 4.6.3 Spark Arresters.

**4.6.3.1** Spark arresters, where required by the AHJ for chimneys attached to solid fuel-burning equipment, shall meet the following requirements:

- (1) The net free area of the arrester shall be not less than three times the net free area of the outlet of the chimney flue it serves.
- (2) The arrester screen shall have heat and corrosion resistance equivalent to 19 gauge [0.041 in. (1.04 mm)] galvanized steel or 24 gauge [0.024 in. (0.61 mm)] stainless steel.
- (3) Openings shall not allow the passage of spheres having a diameter larger than ½ in. (12.7 mm) or block the passage of spheres having a diameter of less than ⅜ in. (9.5 mm).
- (4) The spark screen shall be accessible for cleaning, and the screen or chimney cap shall be removable to allow cleaning of the chimney flue.

**4.6.3.2** Where part of a listed chimney termination system, spark arresters shall be constructed and installed in accordance with the listing.

## Chapter 5 Selection of Chimney and Vent Types

### 5.1 Chimney Types.

**5.1.1 Selection.** Chimney selection shall be limited to three basic chimney types: factory-built, masonry, and unlisted metal [see Figure 5.1.1(a) through Figure 5.1.1(c)].

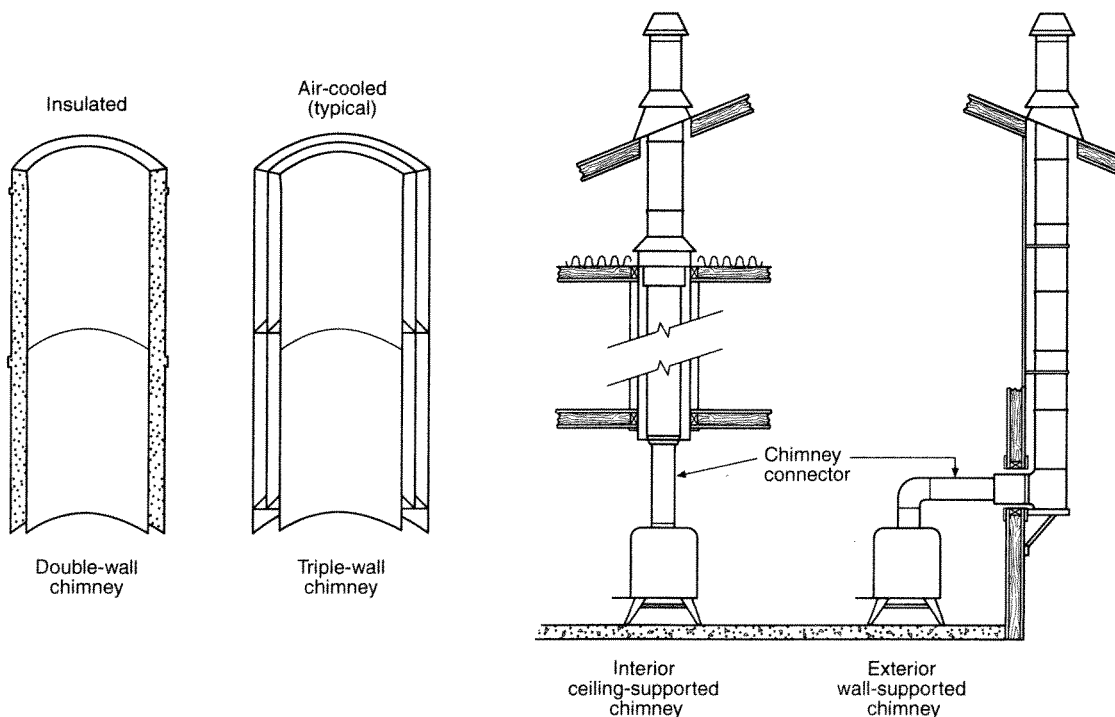

FIGURE 5.1.1(a) Typical Factory-Built Chimney Installation in a Single-Family Residence.

**9.4.3** A connector or manifold serving two or more appliances shall have an effective area equivalent to the combined areas of the appliance flue collars or individual connectors, unless it is part of an engineered venting system.

### 9.5 Clearance.

**9.5.1** Clearances from connectors to combustible material shall be in accordance with the requirements of 9.5.1.1 through 9.5.5.3 for both unprotected and protected installations.

**9.5.1.1** Clearances from connectors to unprotected combustible material shall be in accordance with Table 9.5.1.1 and Figure 9.5.1.1.

**9.5.1.2** Clearances from connectors to combustible material shall be permitted to be reduced, provided the combustible material is protected by an engineered protection system acceptable to the AHJ, using materials or products listed for protection purposes, or is in accordance with Table 9.5.1.2 and Figure 9.5.1.1 chimney or vent connectors.

**9.5.1.2.1** Where the required clearance with no protection is 18 in. (457 mm), clearances shall be permitted to be reduced to the distances in the Minimum Clearance column of Table 9.5.1.2.

**9.5.1.2.2** For other required clearances, calculate the allowable clearance from the Maximum Allowable Reduction in Clearance column of Table 9.5.1.2.

**9.5.1.2.3** Spacers and ties shall meet the following criteria:

- (1) Spacers and ties shall be of noncombustible material.
- (2) No spacers or ties shall be used directly behind an appliance or a connector.

**9.5.1.2.4** Mineral wool batts (blanket or board) shall have a minimum density of 8 lb/ft<sup>3</sup> (128.7 kg/m<sup>3</sup>) and have a minimum melting point of 1500°F (816°C).

**9.5.1.2.5** Insulation material used as part of a clearance reduction system shall have a thermal conductivity of 1.0 Btu-in./hr-ft<sup>2</sup>-°F (4.88 kg-cal/hr-m<sup>2</sup>-°C) or less. Insulation board shall be formed of noncombustible material.

**9.5.1.2.6** If a single-wall connector passes through a masonry wall used as a wall shield, there shall be at least ½ in. (12.7 mm) of open, ventilated air space between the connector and the masonry.

**9.5.1.2.7** There shall be at least 1 in. (25.4 mm) between the connector and the protector.

**9.5.1.2.8** In no case shall the clearance between the connector and the wall surface be reduced below that allowed in Table 9.5.1.2.

**9.5.2\*** Engineered systems installed for the protection of combustible materials shall reduce the temperature rise of such materials to 90°F (50°C) above ambient.

**9.5.3** The following shall apply to clearance protection material:

- (1) All clearances shall be measured from the outer surface of the connector to the combustible material, disregarding any intervening protection applied to the combustible material.
- (2) The clearance protection material shall not interfere with the accessibility of the connector.

**Table 9.5.1.1 Chimney Connector and Vent Connector Clearances from Combustible Materials**

Description of Appliance	Minimum Clearance <sup>a</sup>	
	in.	mm
<b>Residential-Type Appliances</b>		
<i>Single-Wall Metal Pipe Connectors</i>		
Gas appliances without draft hoods	18	457
Electric, gas, and oil incinerators	18	457
Oil and solid-fuel appliances	18	457
Unlisted gas appliances with draft hoods	9	229
Boilers and furnaces equipped with listed gas burners and with draft hoods	9	229
Oil appliances listed as suitable for use with Type L vents	9	229
Listed gas appliances with draft hoods and other Category I gas appliances listed for use with Type B vents <sup>c</sup>	6	152
<i>Type L Vent Piping Connectors</i>		
Gas appliances without draft hoods	9	229
Electric, gas, and oil incinerators	9	229
Oil and solid-fuel appliances	9	229
Unlisted gas appliances with draft hoods	6	152
Boilers and furnaces equipped with listed gas burners and with draft hoods	6	152
Oil appliances listed as suitable for use with Type L vents <sup>b</sup>		
Listed gas appliances with draft hoods and other Category I gas appliances listed for use with Type B vents <sup>c</sup>		
<i>Type B Gas Vent Piping Connectors</i>		
Listed gas appliances with draft hoods and other Category I gas appliances listed for use with Type B vents <sup>c</sup>		
<b>Low-Heat Appliances</b>		
<i>Single-Wall Metal Pipe Connectors</i>		
Gas, oil, and solid-fuel boilers, furnaces, and water heaters	18	457
Restaurant-type ranges	18	457
Oil unit heaters	18	457
Unlisted gas unit heaters	18	457
Listed gas unit heaters with draft hoods	6	152
Other low-heat nonresidential appliances	18	457
<b>Medium-Heat Appliances</b>		
<i>Single-Wall Metal Pipe Connectors</i>		
All gas, oil, and solid-fuel appliances	36	914
<b>High-Heat Appliances</b>		
<i>Masonry or Metal Connectors</i>		
All gas, oil, and solid-fuel appliances <sup>d</sup>		

<sup>a</sup> If the listing of an appliance specifies a different clearance, the listed clearance takes precedence.

<sup>b</sup> If listed Type L vent piping is used, the clearance is permitted to be in accordance with the vent listing.

<sup>c</sup> If listed Type B or Type L vent piping is used, the clearance is permitted to be in accordance with the appliance and vent listing.

<sup>d</sup> See 9.5.1.2.

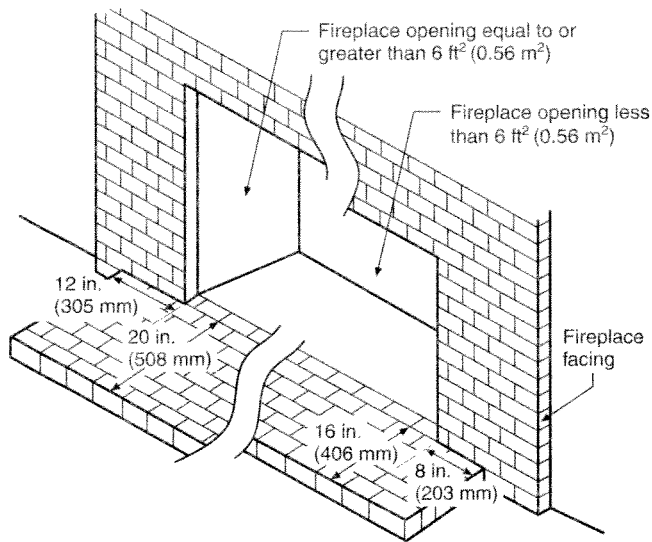

**FIGURE 11.3.3 Fireplace Hearth Extension Requirements.**

**11.3.5** Where a fireplace is elevated above or overhangs a floor, the hearth extension also shall extend over the area under the fireplace.

**11.4\* Accessories.** Fireplace accessories shall be one of the following:

- (1) Listed and installed in accordance with the terms of their listing
- (2) Acceptable to the AHJ and installed as approved and in accordance with the manufacturer's installation instructions

### 11.5 Combustion Air Ducts.

**11.5.1** Where required by the AHJ, combustion air ducts shall be installed in accordance with this section.

**11.5.1.1** Combustion air ducts for factory-built fireplaces shall be a listed component of the fireplace and shall be installed according to the manufacturer's instructions.

**11.5.1.2** Listed combustion air duct systems for masonry fireplaces shall be installed according to the terms of their listing and the manufacturers' instructions.

**11.5.2** Combustion air ducts shall extend as directly as practicable from the outdoors (inlet) to a termination outside the fire chamber (outlet).

**11.5.3** Combustion air ducts shall be constructed of one of the following:

- (1) Masonry
- (2) Galvanized steel with a thickness not less than 26 gauge [0.019 in. (0.483 mm)]
- (3) Other approved noncombustible material

**11.5.4** Combustion air ducts shall be equipped with a damper that is capable of being fully closed.

**11.5.5** Combustion air ducts that terminate outside the fire chamber but within 6 in. (152 mm) of the fire chamber shall be designed and installed to prevent the direct entry of flame, embers, or ashes from the fire chamber into the duct.

**11.5.6** Unlisted combustion air ducts shall be installed with a minimum 1 in. (25.4 mm) clearance to combustibles for all parts of the duct construction within 5 ft (1.53 m) of the duct outlet.

**11.5.7** The exterior inlet of the combustion air duct shall be screened.

**11.5.8** Combustion air ducts shall not originate in any of the following:

- (1) Attic
- (2) Basement
- (3) Garage
- (4) Other interior space

## Chapter 12 Solid Fuel-Burning Appliances

**12.1 Appliances.** Solid fuel-burning appliances shall be one of the following:

- (1) Listed and installed in accordance with the terms of their listing and this chapter
- (2) Approved by the AHJ

**12.1.1** Unlisted appliances approved by the AHJ shall be installed as follows:

- (1) In accordance with the manufacturer's instructions
- (2) As specified in this chapter

**12.1.2** The requirements in 12.1.1 shall not apply to mobile home installations.

### 12.2 Location of Appliances.

**12.2.1\*** Every appliance shall be located with respect to building construction and other equipment to allow access to the appliance.

**12.2.2** Solid fuel-burning appliances shall not be installed in alcoves or enclosed spaces less than 512 ft<sup>3</sup> (14.5 m<sup>3</sup>) unless specifically listed for such use.

**12.2.2.1** Solid fuel-burning appliances listed for installation in enclosed spaces or alcoves less than 512 ft<sup>3</sup> (14.5 m<sup>3</sup>) shall be installed in accordance with the requirements of the listing and the manufacturer's instructions.

**12.2.2.2** The space or room shall be sized to allow circulation of heated air.

**12.2.2.3** Appliances shall be so located as not to interfere with the circulation of air within the heated space.

**12.2.3** Solid fuel-burning appliances shall not be installed in any location where gasoline or any other flammable vapors or gases are present.

**12.2.4** Solid fuel-burning appliances shall not be installed in any garage.

### 12.3 Air for Combustion and Ventilation.

**12.3.1** Solid fuel-burning appliances shall be installed in a location and manner so as to provide ventilation and combustion air supply to allow proper combustion of fuel, chimney draft, and maintenance of safe temperatures.

**12.3.2** Where buildings are so tight that normal infiltration does not provide the necessary air, outside air shall be introduced.

## 12.4 Chimney Connections and Usage.

**12.4.1 Chimney Connection.** All solid fuel-burning appliances shall be connected to chimneys in accordance with Chapter 9.

**12.4.1.1** The chimney provided shall be in accordance with Table 5.2.2.1.

**12.4.1.2** Galvanized steel pipe shall not be used for solid fuel-burning appliances.

**12.4.2 Clearance.** The clearance of chimney connectors to combustible material shall be in accordance with Table 9.5.1.1.

**12.4.3 Inspection and Cleaning Access.** Connectors and chimneys for solid fuel-burning appliances shall be designed, located, and installed to allow access for internal inspection and cleaning.

**12.4.4\* Flue Cross-Sectional Area.** For residential-type, natural draft solid fuel-burning appliances, the flue shall meet the following conditions:

- (1) The cross-sectional area of the flue shall not be less than the cross-sectional area of the appliance flue collar, unless specified by the appliance manufacturer.
- (2) The cross-sectional area of the flue of a chimney with no walls exposed to the outside below the roofline shall not be more than three times the cross-sectional area of the appliance flue collar.
- (3) The cross-sectional area of the flue of a chimney with one or more walls exposed to the outside below the roofline shall not be more than two times the cross-sectional area of the appliance flue collar.

## 12.4.5 Connection to Masonry Fireplaces.

**12.4.5.1** A natural draft solid fuel-burning appliance such as a stove or insert shall be permitted to use a masonry fireplace flue where the following conditions are met:

- (1) There is a connector that extends from the appliance to the flue liner.
- (2) Any unexposed metal that is used as a connector and is exposed to flue gases is constructed of stainless steel or other equivalent material that resists corrosion, softening, or cracking from flue gases at temperatures up to 1800°F (982°C).
- (3) The cross-sectional area of the flue is no smaller than the cross-sectional area of the flue collar of the appliance, unless otherwise specified by the appliance manufacturer.
- (4)\*The cross-sectional area of the flue of a chimney with no walls exposed to the outside below the roofline is no more than three times the cross-sectional area of the appliance flue collar.
- (5) The cross-sectional area of the flue of a chimney with one or more walls exposed to the outside below the roofline is no more than two times the cross-sectional area of the appliance flue collar.
- (6) If the appliance vents directly through the chimney wall above the smoke chamber, there is a noncombustible seal below the entry point of the connector.
- (7) The installation is such that the chimney system can be inspected and cleaned.
- (8) Means are provided to prevent dilution of combustion products in the chimney flue with air from the habitable space.

**12.4.5.2** Listed fireplace accessories shall be permitted to use a masonry fireplace flue in accordance with their listing.

**12.4.6 Existing Flue Use.** Another solid fuel-burning appliance shall not be installed using an existing flue serving a factory-built fireplace unless the appliance is specifically listed for such installation.

## 12.5 Mounting.

### 12.5.1 Mounting for Residential-Type Appliances.

#### 12.5.1.1 General Requirements.

**12.5.1.1.1** Residential-type solid fuel-burning appliances that are tested and listed by a recognized testing laboratory for installation on floors constructed of combustible materials shall be placed on floors in accordance with the requirements of the listing and the conditions of approval.

**12.5.1.1.2** Appliances that are not listed by a recognized testing laboratory shall be provided with floor protection in accordance with the provisions of 12.5.1.2 or 12.5.1.3.

**12.5.1.1.3** Residential-type solid fuel-burning appliances shall be permitted to be placed without floor protection in any of the following manners:

- (1) On concrete bases adequately supported on compacted soil, crushed rock, or gravel
- (2) On concrete slabs or masonry arches that do not have combustible materials attached to the underside
- (3) On approved assemblies constructed of only noncombustible materials and having a fire resistance rating of not less than 2 hours, with floors constructed of noncombustible material
- (4) On properly stabilized ground that can support the load of the appliance

**12.5.1.1.4** Any floor assembly, slab, or arch shall extend not less than 18 in. (457 mm) beyond the appliance on all sides.

**12.5.1.1.5** In lieu of the requirements for floor protection specified herein, a floor protector listed by a recognized testing laboratory and installed in accordance with the installation instructions shall be permitted to be employed.

**12.5.1.1.6** Concrete bases, concrete slabs, masonry arches, and floor-ceiling assemblies and their supports shall be designed and constructed to support the appliances.

#### 12.5.1.2 Room Heaters, Fireplace Stoves, Room Heater/Fireplace Stove Combinations, and Ranges.

**12.5.1.2.1** Room heaters, fireplace stoves, room heater/fireplace stove combinations, or ranges that are set on legs or pedestals that provide not less than 6 in. (152 mm) of ventilated open space beneath the fire chamber or base of the appliance shall be permitted to be placed on floors of combustible construction, provided the following conditions exist:

- (1) The floor under the appliance is protected with closely spaced solid masonry units not less than 2 in. (51 mm) in thickness.
- (2) The top surface of the masonry is covered with sheet metal not less than 24 gauge [0.024 in. (0.61 mm)].
- (3) The floor protection extends not less than 18 in. (457 mm) beyond the appliance on all sides.

**12.5.1.2.2** Room heaters, fireplace stoves, room heater/fireplace stove combinations, or ranges that are set on legs or pedestals providing 2 in. to 6 in. (51 mm to 152 mm) of ventilated open space beneath the fire chamber or base of the appliance shall be permitted to be placed on floors of combustible construction, provided the following conditions exist:

- (1) The floor under the appliance is protected with one course of hollow masonry units not less than 4 in. (102 mm) in nominal thickness.

- (2) The masonry units are laid with ends unsealed and joints matched in such a way as to provide free circulation of air through the core spaces of the masonry.
- (3) The top surface of the masonry is covered with sheet metal not less than 24 gauge [0.024 in. (0.61 mm)].
- (4) The floor protection extends not less than 18 in. (457 mm) beyond the appliance on all sides.

**12.5.1.2.3** Room heaters, fireplace stoves, room heater/fireplace stove combinations, or ranges with legs or pedestals that provide less than 2 in. (51 mm) of ventilated open space beneath the fire chamber or base of the appliance shall not be placed on floors of combustible construction.

### 12.5.1.3 Furnaces and Boilers.

**12.5.1.3.1** Furnaces or boilers with legs or pedestals that provide not less than 6 in. (152 mm) of ventilated open space beneath the fire chamber or base of the appliance shall be permitted to be placed on floors of combustible construction, provided the floor under the appliance has the following characteristics:

- (1) It is protected with one course of hollow masonry units not less than 4 in. (102 mm) in thickness.
- (2) The masonry units are laid with ends unsealed and joints matched in such a way as to provide free circulation of air through the core spaces of the masonry.
- (3) The top surface of the masonry is covered with a steel plate not less than  $\frac{3}{16}$  in. (4.8 mm) in thickness.
- (4) The floor protection extends not less than 18 in. (457 mm) beyond the appliance on all sides.

**12.5.1.3.2** Furnaces or boilers that are set on legs or pedestals that provide 2 in. to 6 in. (51 mm to 152 mm) of ventilated open space beneath the fire chamber or base of the appliance shall be permitted to be placed on floors of combustible construction, provided the floor under the appliance has the following characteristics:

- (1) It is protected with two courses of hollow masonry units, each not less than 4 in. (102 mm) in thickness.
- (2) The masonry units are laid with ends unsealed and joints matched in such a way as to provide free circulation of air through the core spaces of the masonry.
- (3) The top surface of the masonry is covered with a steel plate not less than  $\frac{3}{16}$  in. (4.8 mm) in thickness.
- (4) The floor protection extends not less than 18 in. (457 mm) beyond the appliance on all sides.

**12.5.1.3.3** Furnaces or boilers with legs or pedestals that provide less than 2 in. (51 mm) of ventilated open space beneath the fire chamber or base of the appliance shall not be placed on floors of combustible construction.

### 12.5.2 Mounting for Low-Heat Nonresidential Appliances.

**12.5.2.1** Low-heat nonresidential solid fuel-burning appliances that have been tested and listed by a recognized testing laboratory for placement on floors constructed with a combustible material shall be placed on floors in accordance with the requirements of the listing and conditions of approval.

**12.5.2.1.1** Appliances that are not listed by a recognized testing laboratory shall be provided with floor protection in accordance with the provisions of 12.5.2.3 or 12.5.2.4.

**12.5.2.1.2** Low-heat nonresidential solid fuel-burning appliances shall be permitted to be placed without floor protection in any of the following manners:

- (1) On floors constructed of noncombustible materials that have a fire resistance rating of not less than 2 hours and that extend not less than 18 in. (457 mm) beyond the appliance on all sides
- (2) On concrete bases adequately supported on compacted soil, crushed rock, or gravel
- (3) On properly stabilized ground that can support the load of the appliance

**12.5.2.2** Concrete bases, concrete slabs, and floors shall be designed and constructed to support the appliances.

**12.5.2.3** Low-heat nonresidential solid fuel-burning appliances that are set on legs or pedestals that provide not less than 18 in. (457 mm) of ventilated open space beneath the fire chamber or base of the appliance shall be permitted to be placed on floors of combustible construction, provided the following conditions exist:

- (1) The floor under the appliance is protected with one course of hollow masonry units not less than 4 in. (102 mm) in thickness.
- (2) The masonry units are laid with ends unsealed and joints matched in such a way as to provide free circulation of air through the core spaces of the masonry.
- (3) The top surface of the masonry is covered with a steel plate not less than  $\frac{3}{16}$  in. (4.8 mm) in thickness.
- (4) The floor protection extends not less than 18 in. (457 mm) beyond the appliance on all sides.

**12.5.2.4** Low-heat nonresidential solid fuel-burning appliances that are set on legs or pedestals that provide 6 in. to 18 in. (152 mm to 457 mm) of ventilated open space beneath the fire chamber or base of the appliance shall be permitted to be placed on floors of combustible construction, provided the following conditions exist:

- (1) The floor under the appliance is protected with two courses of hollow masonry units, each not less than 4 in. (102 mm) in thickness.
- (2) The masonry units are laid with ends unsealed and joints matched in such a way as to provide free circulation of air through the core spaces of the masonry.
- (3) The top surface of the masonry is covered with a steel plate not less than  $\frac{3}{16}$  in. (4.8 mm) in thickness.
- (4) The floor protection extends not less than 18 in. (457 mm) beyond the appliance on all sides.

**12.5.2.5** Low-heat nonresidential solid fuel-burning appliances with legs or pedestals that provide less than 6 in. (152 mm) of ventilated open space beneath the fire chamber or base of the appliance shall not be placed on floors of combustible construction.

### 12.5.3 Mounting for Medium-Heat Nonresidential Appliances.

**12.5.3.1** Medium-heat nonresidential solid fuel-burning appliances that have been tested and listed by a recognized testing laboratory for placement on floors constructed with a combustible material shall be placed on floors in accordance with the requirements of the listing and conditions of approval.

**12.5.3.1.1** Appliances that are not listed by a recognized testing laboratory shall be provided with floor protection in accordance with the provisions of 12.5.3.3 or 12.5.3.4.

**12.5.3.1.2** Medium-heat nonresidential solid fuel-burning appliances shall be permitted to be placed without floor protection in any of the following manners:



- (1) On concrete bases adequately supported on compacted soil, crushed rock, or gravel
- (2) On floors constructed of noncombustible materials that have a fire resistance rating of not less than 2 hours and that extend not less than 3 ft (0.92 m) beyond the appliance on all sides and 8 ft (2.45 m) beyond the front or side where ashes are removed
- (3) On properly stabilized ground that can support the load of the appliance

**12.5.3.2** Concrete bases, concrete slabs, and floors shall be designed and constructed to support the appliances.

**12.5.3.3** Medium-heat nonresidential solid fuel-burning appliances that are set on legs or pedestals that provide not less than 24 in. (610 mm) of ventilated open space beneath the fire chamber or base of the appliance shall be permitted to be placed on floors of combustible construction, provided the floor under the appliance has the following characteristics:

- (1) It is protected with one course of hollow masonry units not less than 4 in. (102 mm) in thickness.
- (2) The masonry units are laid with ends unsealed and joints matched in such a way as to provide free circulation of air through the core spaces of the masonry.
- (3) The top surface of the masonry is covered with a steel plate not less than  $\frac{3}{16}$  in. (4.8 mm) in thickness.
- (4) The floor protection extends not less than 3 ft (0.92 m) beyond the appliance on all sides and 8 ft (2.45 m) beyond the front or side where ashes are removed.

**12.5.3.4** Medium-heat nonresidential solid fuel-burning appliances that are set on legs or pedestals that provide 18 in. to 24 in. (457 mm to 610 mm) of ventilated open space beneath the fire chamber or base of the appliance shall be permitted to be placed on floors of combustible construction, provided the floor under the appliance has the following characteristics:

- (1) It is protected with two courses of hollow masonry units, each not less than 4 in. (102 mm) in thickness.
- (2) The masonry units are laid with ends unsealed and joints matched in such a way as to provide free circulation of air through the core spaces of the masonry.
- (3) The top surface of the masonry is covered with a steel plate not less than  $\frac{3}{16}$  in. (4.8 mm) in thickness.
- (4) The floor protection extends not less than 3 ft (0.92 m) beyond the appliance on all sides and 8 ft (2.45 m) beyond the front or side where ashes are removed.

**12.5.3.5** Medium-heat nonresidential solid fuel-burning appliances with legs or pedestals that provide less than 18 in. (457 mm) of ventilated open space beneath the fire chamber or base of the appliance shall not be placed on floors of combustible construction.

#### **12.5.4 Mounting of High-Heat Nonresidential Appliances.**

**12.5.4.1** High-heat nonresidential solid fuel-burning appliances shall be placed in one of the following manners:

- (1) On concrete bases adequately supported on compacted soil, crushed rock, or gravel
- (2) On floors constructed of noncombustible materials that have a fire resistance rating of not less than 2 hours and that extend not less than 10 ft (3.1 m) beyond the appliance on all sides and not less than 30 ft (9.2 m) beyond the front or side where hot products are removed
- (3) On properly stabilized ground that can support the load of the appliance

**12.5.4.2** Concrete bases and floors shall be designed and constructed to support the appliances.

**12.5.4.3** High-heat nonresidential solid fuel-burning appliances shall not be placed on floors of combustible construction.

#### **12.6 Clearances from Solid Fuel-Burning Appliances.**

**12.6.1** The clearance shall be not less than specified in Table 12.6.1.

**12.6.1.1** Appliances listed for installation with clearances less than specified in Table 12.6.1 shall be permitted to be installed in accordance with the terms of their listing and the manufacturer's instructions.

**12.6.1.2** Heating furnaces and boilers and water heaters specifically listed for installation in spaces such as alcoves shall be permitted to be so installed in accordance with the terms of their listing, provided the specified clearance is maintained regardless of whether the enclosure is of combustible or noncombustible material.

**12.6.1.3** These clearances shall apply to appliances installed in rooms that are large in comparison with the size of the appliances.

#### **12.6.2 Clearance Reduction.**

**12.6.2.1** Clearances from listed and unlisted solid fuel-burning appliances to combustible material shall be permitted to be reduced if the combustible material is protected as described in Table 12.6.2.1 and in Figure 12.6.2.1(a) through Figure 12.6.2.1(f).

**12.6.2.1.1** Where the required clearance with no protection is 36 in. (914 mm), the clearances in Table 12.6.2.1 shall be the minimum allowable clearances. For other required clearances with no protection, minimum allowable clearance shall be calculated from maximum allowable reduction.

**12.6.2.1.2** Unless the appliance is specifically listed for lesser clearance, the clearance after reduction shall be not less than the following:

- (1) 12 in. (305 mm) to combustible walls
- (2) 18 in. (457 mm) to combustible ceilings

**12.6.2.1.3** Spacers and ties shall be of noncombustible material. No spacers or ties shall be used directly behind appliance or conductor.

**12.6.2.1.4** With all clearance reduction systems using a ventilated air space, adequate air circulation shall be provided as described in 12.6.2.4. There shall be at least 1 in. (25.4 mm) between the clearance reduction system and combustible walls and ceilings for clearance reduction systems using a ventilated air space.

**12.6.2.1.5** Mineral wool batts (blanket or board) shall have a minimum density of 8 lb/ft<sup>3</sup> (128.7 kg/m<sup>3</sup>) and have a minimum melting point of 1500°F (816°C).

**12.6.2.1.6** Insulation material used as part of clearance reduction system shall have a thermal conductivity of 1.0 Btu-in./hr-ft<sup>2</sup>-°F (4.88 kg-cal/hr-m<sup>2</sup>-°C) or less. Insulation board shall be formed of noncombustible material.

**12.6.2.1.7** If a single-wall connector passes through a masonry wall used as a wall shield, there shall be at least  $\frac{1}{2}$  in. (13 mm) of open, ventilated air space between the connector and the masonry.

Table 12.6.1 Standard Clearances for Solid Fuel-Burning Appliances

Type of Appliance	Above Top of Casing or Appliance; Above Top and Sides of Furnace Plenum or Bonnet		From Front		From Back <sup>a</sup>		From Sides <sup>a</sup>	
	in.	mm	in.	mm	in.	mm	in.	mm
<i>Residential Appliances</i>	6	152	48	1219	6 <sup>b</sup>	152 <sup>b</sup>	6 <sup>b</sup>	152 <sup>b</sup>
Steam boilers — 15 psi (103 kPa)								
Water boilers — 250°F (121°C) max.								
Water boilers — 200°F (93°C) max.								
All water walled or jacketed appliances								
<i>Furnaces</i>								
Gravity and forced air <sup>c</sup>	18	457	48	1219	18	457	18	457
<i>Room Heaters, Fireplace Stoves, Room Heater/Fireplace Stove Combinations, Ranges</i>	36	914	36	914	36	914	36	914
Lined fire chamber	30 <sup>d</sup>	762 <sup>d</sup>	36	914	Firing Side 24 610		Opposite Side 18 457	
Unlined fire chamber	30 <sup>d</sup>	762 <sup>d</sup>	36	914	36 914		18 457	

<sup>a</sup> Provisions for fuel storage shall be located at least 36 in. (914 mm) from any side of the appliance.

<sup>b</sup> Adequate clearance for cleaning and maintenance shall be provided.

<sup>c</sup> For clearances from air ducts, see NFPA 90B, *Standard for the Installation of Warm Air Heating and Air-Conditioning Systems*.

<sup>d</sup> Clearance to combustible material or metal cabinets. If the underside of such combustible material or metal cabinet is protected with sheet metal of not less than 24 gauge [0.024 in. (0.61 mm)], spaced out 1 in. (25.4 mm), the distance shall be permitted to be reduced to not less than 24 in. (610 mm).

Table 12.6.2.1 Reduction of Appliance Clearance with Specified Forms of Protection

Clearance Reduction Applied to and Covering All Combustible Surfaces Within the Distance Specified as Required Clearance with No Protection*	Maximum Allowable Reduction in Clearance (%)		Minimum Clearance			
	As Wall Protector	As Ceiling Protector	As Wall Protector		As Ceiling Protector	
			in.	mm	in.	mm
(a) 3½ in. (90 mm) thick masonry wall without ventilated air space	33	—	24	610	—	—
(b) ½ in. (13 mm) thick noncombustible insulation board over 1 in. (25.4 mm) glass fiber or mineral wool batts without ventilated air space	50	33	18	457	24	610
(c) 0.024 in. (0.61 mm), 24 gauge sheet metal over 1 in. (25.4 mm) glass fiber or mineral wool batts reinforced with wire or equivalent on rear face with ventilated air space	66	50	12	305	18	457
(d) 3½ in. (90 mm) thick masonry wall with ventilated air space	66	—	12	305	—	—
(e) 0.024 in. (0.61 mm), 24 gauge sheet metal with ventilated air space	66	50	12	305	18	457
(f) ½ in. (13 mm) thick noncombustible insulation board with ventilated air space	66	50	12	305	18	457
(g) 0.024 in. (0.61 mm), 24 gauge sheet metal with ventilated air space over 0.024 in. (0.61 mm), 24 gauge sheet metal with ventilated air space	66	50	12	305	18	457
(h) 1 in. (25.4 mm) glass fiber or mineral wool batts sandwiched between two sheets 0.024 in. (0.61 mm), 24 gauge sheet metal with ventilated air space	66	50	12	305	18	457

## Notes:

(1) All clearances and thicknesses are minimums; larger clearances and thicknesses are permitted.

(2) To calculate the minimum allowable clearance, the following formula can be used:  $C_{pr} = C_{un} \times [1 - (R/100)]$ , where  $C_{pr}$  is the minimum allowable clearance,  $C_{un}$  is the required clearance with no protection, and  $R$  is the maximum allowable reduction in clearance.

(3) Refer to Figure 12.6.2.1(e) and Figure 12.6.2.1(f) for other reduced clearances using materials found in this table.

\*See 12.6.1 through 12.6.1.3.

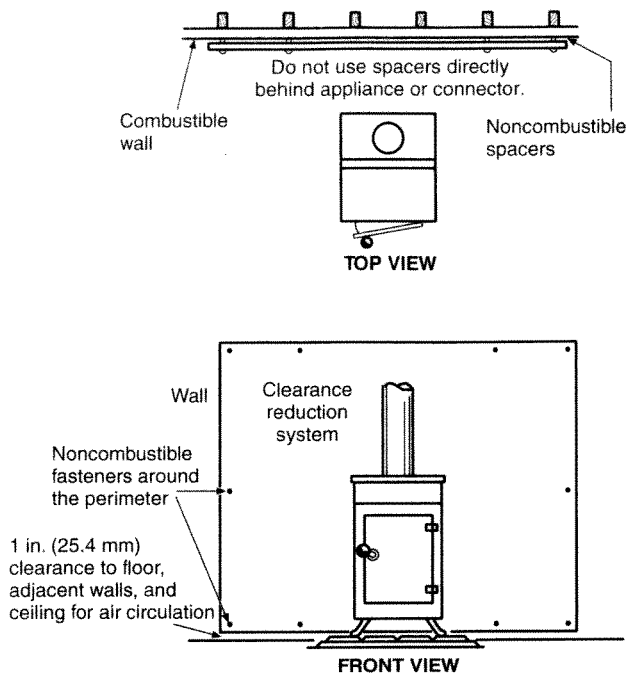

FIGURE 12.6.2.1(a) Clearance Reduction System — Fastener Location.

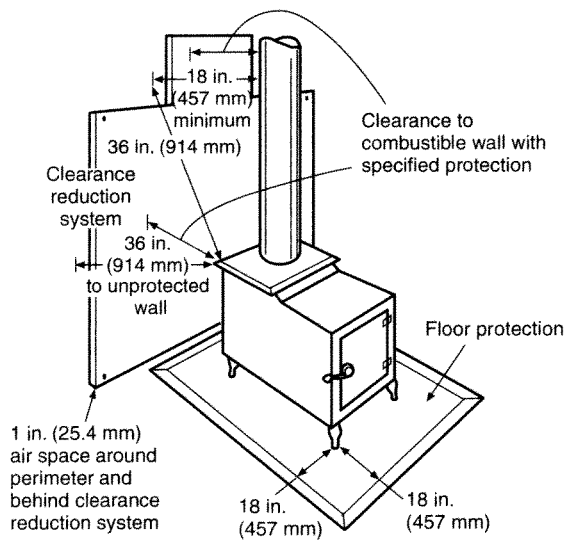

FIGURE 12.6.2.1(b) Distance to Combustible Wall/Floor.

**12.6.2.1.8** There shall be at least 1 in. (25.4 mm) between the appliance and the protector. In no case shall the clearance between the appliance and the wall surface be reduced below that allowed in Table 12.6.2.1.

**12.6.2.1.9** Clearances in front of the loading door, ash removal door, or both of the appliance shall not be reduced from those in Section 12.5.

**12.6.2.2** Clearances from solid fuel-burning appliances to combustible material shall be permitted to be reduced, provided the

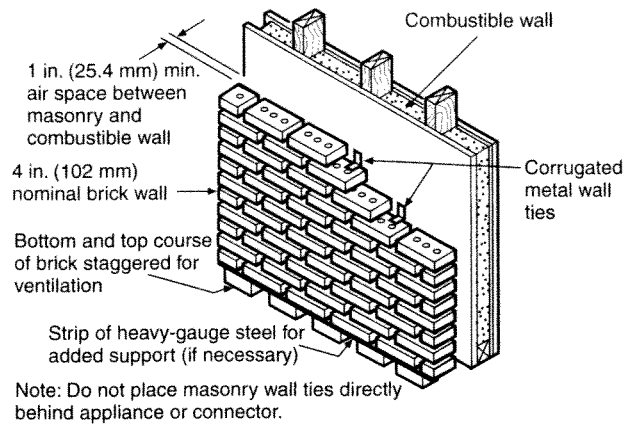
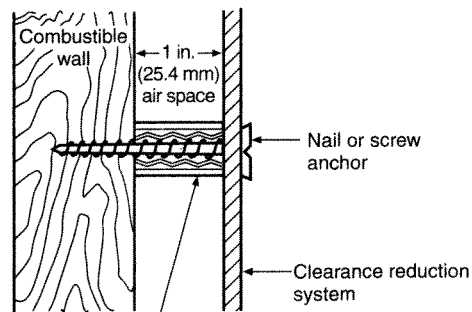
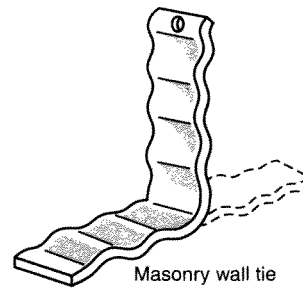

FIGURE 12.6.2.1(c) Masonry Clearance Reduction System.



Notes:

- (1) Masonry walls can be attached to combustible walls using wall ties.
- (2) Do not use spacers directly behind appliance or connector.

FIGURE 12.6.2.1(d) Fastener Detail.

combustible material is protected by an engineered protection system acceptable to the AHJ.

**12.6.2.2.1** Engineered systems installed for the protection of combustible material shall reduce the temperature of such materials to 90°F (50°C) rise above ambient.

**12.6.2.2.2** System design shall be based on applicable heat transfer principles, taking into account the following:

- (1) The geometry of the system

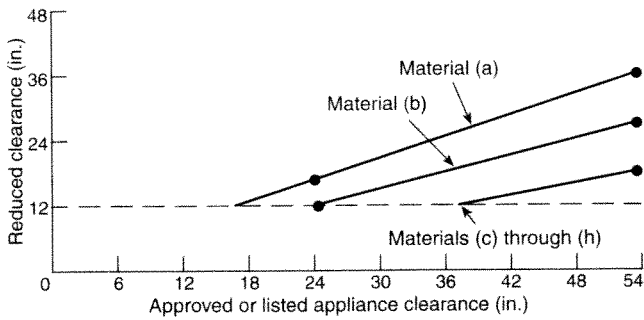

For SI units: 1 in. = 25.4 mm.

FIGURE 12.6.2.1(e) Wall Protection Using Materials in Table 12.6.2.1.

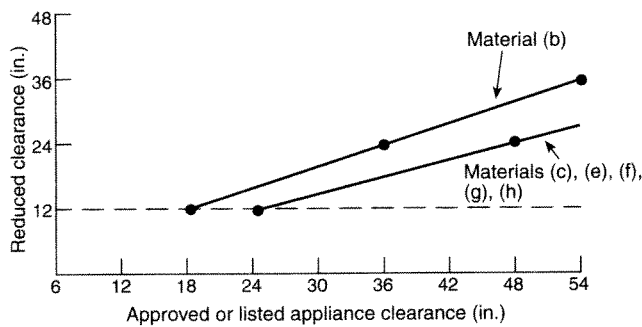

Notes:

- (1) Materials (a) and (d) are not expected to be used as ceiling protection.
- (2) For SI units: 1 in. = 25.4 mm.

FIGURE 12.6.2.1(f) Ceiling Protection Using Materials in Table 12.6.2.1.

- (2) The heat loss characteristics of the structure behind the combustible material
- (3) The possible abnormal operating conditions of the heat-producing sources

12.6.2.3 The following shall apply to clearances from solid fuel-burning appliances to combustible material:

- (1) They shall be permitted to be reduced by the use of materials or products listed for protection purposes.
- (2) Materials and products listed for the purpose of reducing clearance to combustibles shall be installed in accordance with the conditions of the listing and the manufacturer's instructions.

12.6.2.4 For clearance reduction systems using an air space between the combustible wall and the wall protector, adequate air circulation shall be provided by one of the methods outlined in 12.6.2.4.1 through 12.6.2.4.3 and illustrated in Figure 12.6.2.4.

12.6.2.4.1 Air circulation shall be permitted to be provided by leaving all edges of the wall protector open with at least a 1 in. (25.4 mm) air gap.

12.6.2.4.2 If the wall protector is mounted on a single flat wall away from corners, air circulation shall be permitted to be provided by leaving only the bottom and top edges or only the side and top edges open with at least a 1 in. (25.4 mm) air gap.

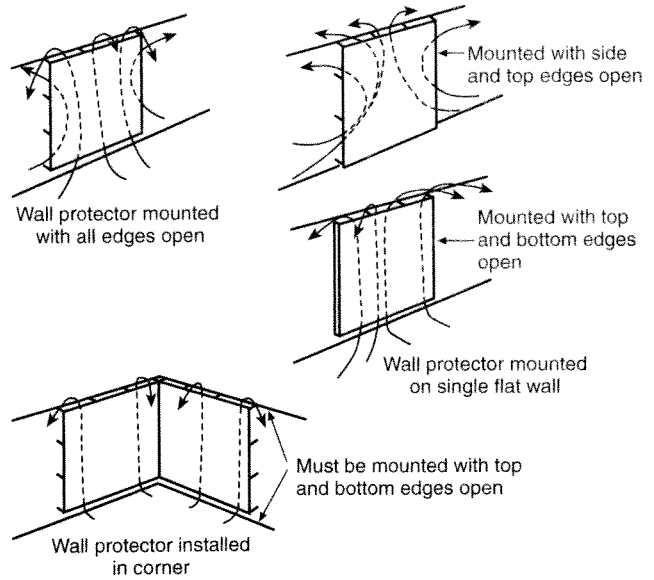

FIGURE 12.6.2.4 Air Circulation Methods.

12.6.2.4.3 Wall protectors that cover two walls in a corner shall be open at the bottom and top edges with at least a 1 in. (25.4 mm) air gap.

12.6.2.5 All clearances shall be measured from the outer surface of the combustible material to the nearest point on the surface of the solid fuel-burning appliance, disregarding any intervening protection applied to the combustible material.

12.6.2.6 All clearances provided between solid fuel-burning appliances and combustible materials shall be large enough to maintain sufficient clearances between chimney connectors and combustible material as required in Section 9.5.

12.7 Accessories.

12.7.1 Factory-built accessories for solid fuel-burning appliances such as heat exchangers, stove mats, floor pads, and protection shields shall be listed and shall be installed in accordance with the terms of their listing.

12.7.2 Unlisted accessories that are acceptable to the AHJ shall be permitted to be installed in accordance with the approval of the AHJ and the appliance and accessory manufacturers' installation instructions.

Chapter 13 Maintenance

13.1 Initial Installation. Initial installation of chimneys, fireplaces, and vents shall allow inspection of the surroundings to determine that the required clearances have been maintained and that correct provisions for support, stabilization, future inspection, and maintenance are in place.

13.2 Annual Inspection. Chimneys, fireplaces, and vents shall be inspected at least once a year in accordance with the requirements of Section 14.3.

Exception: Type B and Type BW gas venting systems.